

HRL Series

HRL12-380W 12V95Ah

Sacred Sun HRL batteries adopt new appearance and constructure design, automatically welding+throug the partition welding+heat sealing technolgy, full automatic production process with good consistency. It has excellent high power discharge, long floating backup time and fast charging performance. It can be widely used in data center, UPS, IDC room.



Benefits

- Very long life according to EUROBAT Classification
- High power density, 30% higher than ordinary batteries
- Special lead paste formual and additives improve the battery service life
- Maximum charge efficiency
- Low self-discharge rate
- Wide range of power, easy sizing of batteries
- Easy installation and handling

Applications

- Data center
- UPS
- IDC room
- Emergency power
- HVDC system

Standards

- IEC 60896-21/22
- JIS C8704-1/2
- EUROBAT guide

Drawing

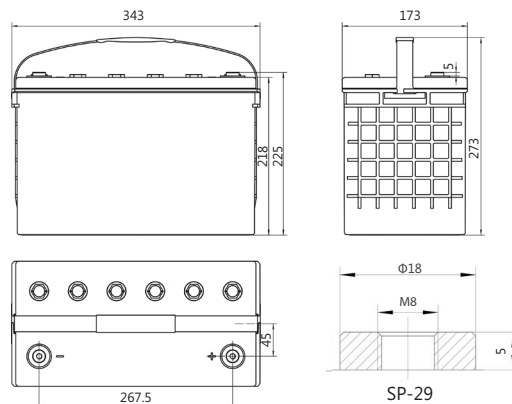

Specifications

Battery Model	HRL12-380W			
Design Life (years, 25°C)	15			
Capacity (Ah, 25°C)	10min (1.60V)	15min (1.67V)	1HR (60A, 1.70V)	10HR(9.5A, 1.80V)
	492	380	60	95
Dimensions (mm)	Length	Width	Height	Total Height
	343	173	218	225
Approx. Weight (kg)	31.7			
Reference Internal Resistance (mΩ)	2.5 (fully charged @ 25°C)			
Maximum Discharge Current (A/3 Sec.)	1150			
Self-Discharge (25°C)	< 2% per month			
Charge Voltage (V/cell, 25°C)	Cycle use		Float use	
	2.35(-3.5mV/°C/cell), max charge current: 23.75A		2.25 (-3.5mV/°C/cell)	
Short Circuit Current (A)	3700			

Discharge Data

Constant Power Discharge Data (25°C, W/cell)																
End Voltage (V/cell)	min							h								
	5	10	15	20	25	30	45	1	1.5	2	3	4	5	6	8	10
1.60	670	492	393	315	265	218	167	123	95.6	77.8	57.0	44.5	36.8	31.7	24.8	20.7
1.65	630	483	386	308	260	215	165	120	94.4	77.2	56.7	44.2	36.6	31.5	24.5	20.5
1.67	620	475	380	304	256	212	162	118	93.4	76.7	56.3	43.8	36.3	31.3	24.4	20.4
1.70	600	464	370	298	250	207	158	117	92.0	75.8	55.7	43.4	36.0	31.0	24.0	20.2
1.75	570	440	350	282	238	198	150	112	88.8	74.0	54.5	42.4	35.2	30.3	23.6	19.7
1.80	530	410	330	264	223	186	142	107	85.0	71.8	53.0	41.2	34.3	29.5	22.8	19.2

Constant Current Discharge Data (25°C, A)																
End Voltage (V/cell)	min							h								
	5	10	15	20	25	30	45	1	1.5	2	3	4	5	6	8	10
1.60	360	280	220	174	144	117	88.2	63.5	49.6	40.3	29.5	22.8	18.8	16.2	12.6	10.5
1.65	355	273	214	170	140	114	86.3	62.3	48.7	39.8	29.0	22.6	18.7	16.0	12.5	10.4
1.67	350	268	210	166	138	112	84.7	61.3	48.0	39.4	28.8	22.4	18.5	15.8	12.3	10.3
1.70	340	260	204	160	134	108	82.6	60.0	47.2	38.8	28.4	22.0	18.3	15.7	12.2	10.2
1.75	320	244	190	150	126	103	77.8	57.0	45.0	37.6	27.6	21.4	17.7	15.3	11.8	9.8
1.80	290	225	176	138	116	96.0	72.2	53.4	42.8	36.0	26.6	20.6	17.0	14.7	11.4	9.5

Performance Curve

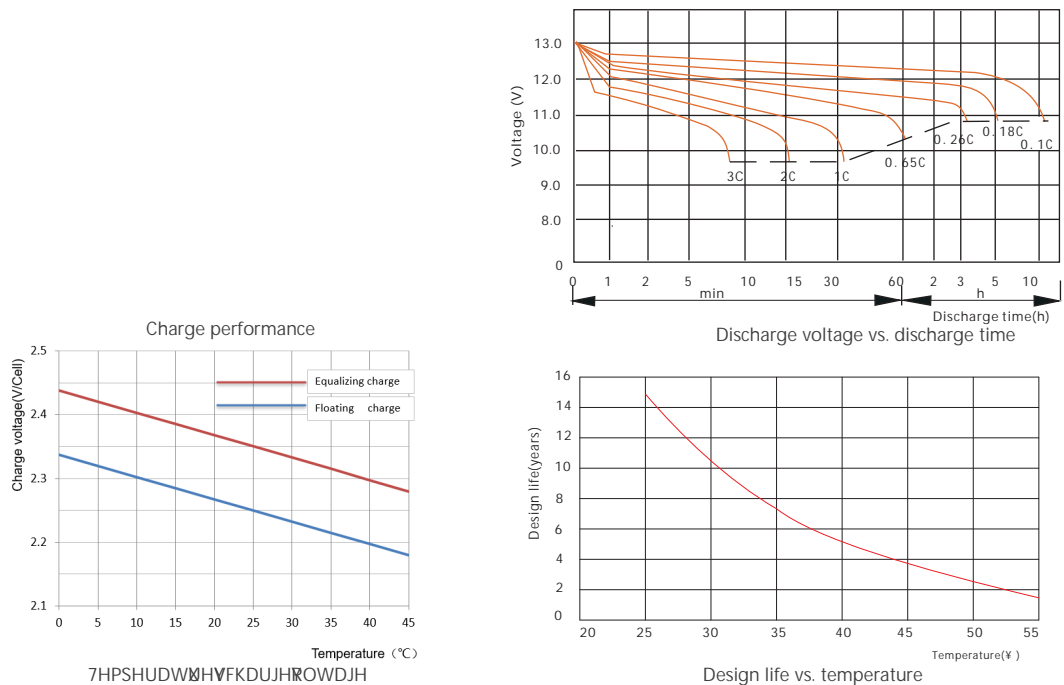

Sacred Sun Power Sources Co., Ltd.

Add: No.1 Shengyang Road, Qufu 273100 PRC
Tel: +86-537-4422313 Fax: +86-537-4411980
Email: sales@sacredsun.cn

Sacred Sun Hong Kong Co., Limited

Add: RM 19C Lockhart CTR 301-307 Lockhart RD Wan Chai, Hong Kong
Email: admin.hk@sacredsun.hk

Sacred Sun Asia Pacific Pte Ltd.

Add: 1 Ubi View, #04-12, Focus One, Singapore 408555
Email: admin.sg@sacredsun.sg

Sacred Sun Europe SARL

Add: ZAE Fontaine, 33210 Fargues, France
Email: admin.eu@sacredsun.eu

Sacred Sun MEA FZE

Add: No. 311 office, Building LOB 14, JAFZA, Dubai, UAE
Email: admin.ae@sacredsun.ae

