

SP Series

SSP12-18 12V18Ah



SP series VRLA battery uses AGM technology and high-purity raw materials. Its good floating back up and large current discharge performance makes it optimal and economical choice for UPS/EPS.

Benefits

- Standard Commercial according to EUROBAT Classification
- Maximum charge efficiency
- High gas recombination efficiency
- Low self-discharge rate
- Easy installation and handling
- Vertical or horizontal installation

Applications

- UPS units
- Emergency power
- Starting generators
- EPS units

Standards

- IEC 61056-1/2
- JIS C8702-1/2
- EUROBAT guide

Drawing

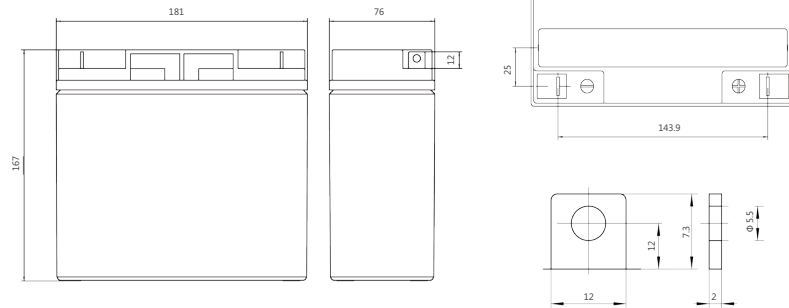

SP-11

Specifications

Battery Model	SSP12-18			
Design Life (years, 25°C)	5			
Capacity (Ah, 25°C)	20HR (0.90A, 1.75V)	10HR (1.67A, 1.75V)	5HR (3.204A, 1.75V)	1HR(11.45A, 1.70V)
	18	16.7	16.02	11.45
Dimensions (mm)	Length	Width	Height	Total Height
	181	76	167	167
Approx. Weight (kg)	5.4			
Reference Internal Resistance (mΩ)	14 (full charged @ 25°C)			
Maximum Discharge Current (A/5 Sec.)	270			
Self-Discharge (25°C)	≤ 3% per month			
Charge Voltage (V/cell, 25°C)	Cycle use		Float use	
	2.45 (-3.5mV/°C/cell), max charge current: 5.4 A		2.27 (-3.5mV/°C/cell)	
Short Circuit Current (A)	460			

Discharge Data

Constant Current Discharge Data (25°C, A)													
End Voltage (V/cell)	min						h						
	5	10	15	20	30	45	1	1.5	2	3	5	10	20
1.60	67.00	46.41	34.18	27.33	19.88	14.77	11.73	8.581	6.900	5.096	3.287	1.709	0.918
1.65	66.00	44.75	33.28	26.83	19.54	14.63	11.57	8.473	6.820	5.032	3.258	1.694	0.911
1.67	63.80	43.45	33.00	26.67	19.43	14.46	11.52	8.424	6.787	5.012	3.249	1.688	0.907
1.70	60.50	42.83	32.69	26.45	19.28	14.41	11.45	8.391	6.753	4.987	3.233	1.684	0.905
1.75	55.00	38.45	30.96	25.38	18.65	13.92	11.20	8.251	6.660	4.938	3.204	1.670	0.900
1.80	47.30	35.18	28.89	24.03	17.90	13.46	10.94	8.110	6.567	4.879	3.169	1.655	0.895

Constant Power Discharge Data (25°C, W/cell)													
End Voltage (V/cell)	min						h						
	5	10	15	20	30	45	1	1.5	2	3	5	10	20
1.60	118.9	84.61	64.37	52.36	38.43	28.79	23.00	16.89	13.628	10.102	6.537	3.405	1.830
1.65	117.7	82.45	63.05	51.55	37.87	28.59	22.73	16.73	13.500	9.997	6.492	3.383	1.823
1.67	115.0	80.47	62.74	51.38	37.73	28.30	22.65	16.66	13.46	9.968	6.481	3.374	1.817
1.70	109.9	79.60	62.39	51.04	37.51	28.23	22.55	16.61	13.41	9.930	6.455	3.370	1.816
1.75	101.3	72.03	59.37	49.13	36.41	27.38	22.12	16.37	13.25	9.850	6.412	3.349	1.808
1.80	87.8	66.55	55.68	46.75	35.06	26.53	21.68	16.12	13.094	9.749	6.353	3.326	1.800

Performance Curve

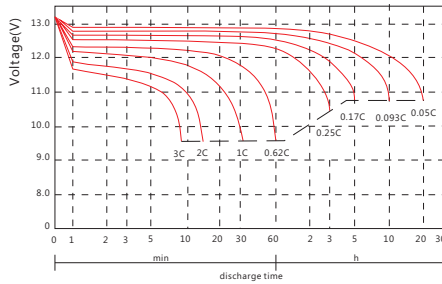

Discharge voltage vs. discharge time

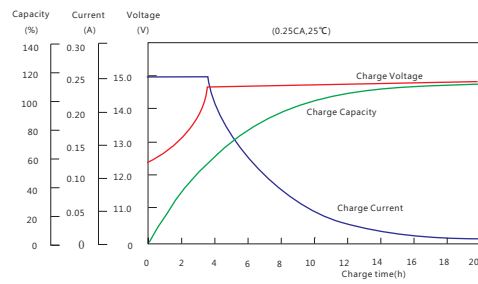

Charge capacity vs. charge time

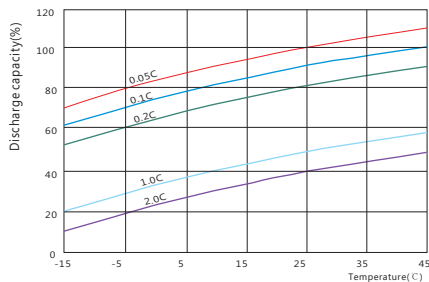

Discharge capacity vs. temperature

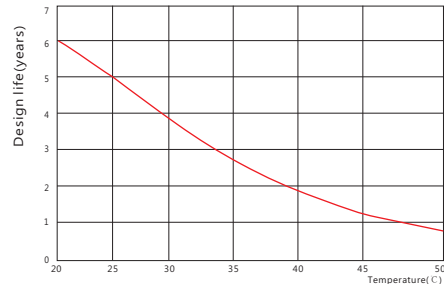

Design life vs. temperature

Sacred Sun Power Sources Co., Ltd.

Add: No.1 Shengyang Road, Qufu 273100 PRC
Tel: +86-537-4422313 Fax: +86-537-4411980
Email: sales@sacredsun.cn

Sacred Sun Hong Kong Co., Limited

Add: RM 19C Lockhart CTR 301-307 Lockhart RD Wan Chai, Hong Kong
Email: admin.hk@sacredsun.hk

Sacred Sun Asia Pacific Pte Ltd.

Add: 1 Ubi View, #04-12, Focus One, Singapore 408555
Email: admin.sg@sacredsun.sg

Sacred Sun Europe SARL

Add: ZAE Fontaine, 33210 Fargues, France
Email: admin.eu@sacredsun.eu

Sacred Sun MEA FZE

Add: No. 311 office, Building LOB 14, JAFZA, Dubai, UAE
Email: admin.ae@sacredsun.ae

